

Upper Bounds on the Bit Error Rate of Optimum Combining in Wireless Systems

Jack H. Winters and Jack Salz
 AT&T Bell Laboratories
 Holmdel, New Jersey 07733 USA

Abstract: This paper presents upper bounds on the bit error rate (BER) of optimum combining in wireless systems with multiple cochannel interferers in a Rayleigh fading environment. We present closed-form expressions for the upper bound on the bit error rate with optimum combining, for any number of antennas and interferers, with coherent detection of BPSK and QAM signals, and differential detection of DPSK. We also present bounds on the performance gain of optimum combining over maximal ratio combining. These bounds are asymptotically tight with decreasing BER, and results show that the asymptotic gain is within 2 dB of the gain as determined by computer simulation for a variety of cases at a 10^{-3} BER. The closed-form expressions for the bound permit rapid calculation of the improvement with optimum combining for any number of interferers and antennas, as compared with the cpu hours previously required by Monte Carlo simulation. Thus, these bounds allow calculation of the performance of optimum combining under a variety of conditions where it was not possible previously, including analysis of the outage probability with shadow fading and the combined effect of adaptive arrays and dynamic channel assignment in mobile radio systems.

I. INTRODUCTION

Antenna arrays with optimum combining combat multipath fading of the desired signal and suppress interfering signals, thereby increasing both the performance and capacity of wireless systems. With optimum combining, the received signals are weighted and combined to maximize the signal-to-interference-plus-noise ratio (SINR) at the receiver. Optimum combining yields superior performance over maximal ratio combining, whereby the signals are combined to maximize signal-to-noise ratio, in interference limited systems. However, while with maximal ratio combining the bit error rate can be expressed in closed form [1], with optimum combining a closed-form expression is available only with one interferer [2-4]. With multiple interferers, Monte Carlo simulation has been used [4-6], but this requires on the order of cpu hours even with just a few interferers. Thus, the improvement of optimum combining has only been studied for a few simple cases, and detailed comparisons (e.g., in terms of outage probability) have not been done.

In [7], we showed that, with M antenna elements, the signals can be combined to eliminate L ($L < M$) interferers with the performance of maximal ratio combining with $M-L$ antennas. However, this "zero-forcing" solution gives far lower output SINR than optimum combining in most cases of interest and cannot be used when $L \geq M$.

In this paper we present a closed-form expression for the upper bound on the bit error rate (BER) with optimum combining in wireless systems. We assume flat fading across the channel and independent Rayleigh fading of the desired and interfering signals at each antenna. Equations are presented for the upper bound on the BER for coherent detection of quadrature amplitude modulated (QAM) and binary phase shift keyed (BPSK) signals, and for differential detection of differential phase shift keyed (DPSK) signals. From these equations, a lower bound on the improvement of optimum combining over maximal ratio combining is derived.

II. UPPER BOUND DERIVATION

Figure 1 shows a block diagram of an M element adaptive array. The complex baseband signal received by the i^{th} antenna element in the k^{th} symbol interval, $x_i(k)$, is multiplied by a controllable complex weight w_i and the weighted signals are summed to form the array output signal $s_o(k)$.

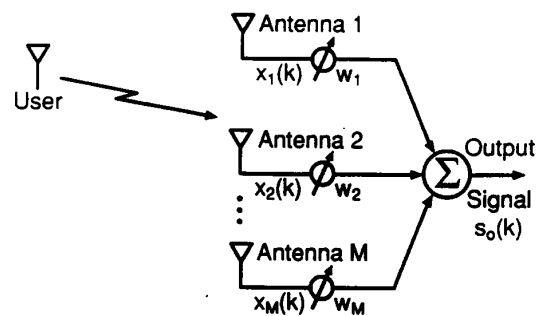

Figure 1 Block diagram of an M element adaptive array.

With optimum combining, the weights are chosen to maximize the output SINR, which also minimizes the mean square error, which is given by [8]

$$MSE = \left[1 + \mathbf{u}_d^T \mathbf{R}_{nn}^{-1} \mathbf{u}_d \right]^{-1}, \quad (1)$$

where \mathbf{R}_{nn} is the received interference-plus-noise correlation matrix given by

$$\mathbf{R}_{nn} = \sigma^2 \mathbf{I} + \sum_{j=1}^L \mathbf{u}_j \mathbf{u}_j^\dagger, \quad (2)$$

σ^2 is the noise power, \mathbf{I} is the identity matrix, \mathbf{u}_d and \mathbf{u}_j are the desired and j^{th} interfering signal propagation vectors, respectively, and the superscript \dagger denotes complex conjugate transpose. Here we have assumed the same average received power for the desired signal at each antenna (that is, microdiversity rather than macrodiversity) and that the noise and interfering signals are uncorrelated, and without loss of generality, have normalized the received signal power, averaged over the fading, to 1. Note that the *MSE* varies at the fading rate.

For coherent detection of BPSK or QAM, the BER, averaged over the Rayleigh fading, is bounded by [9],

$$P_e \leq e^{-\frac{1}{\sigma_c^2}} E \left[e^{-\frac{1}{MSE}} \right] = e^{-\left(\frac{1}{\sigma_c^2} - 1\right)} E \left[e^{-\mathbf{u}_d^\dagger \mathbf{R}_{nn}^{-1} \mathbf{u}_d} \right], \quad (3)$$

where the expected value is taken over the fading parameters of the desired and interfering signals, and σ_c^2 is the variance of the BPSK or QAM symbol levels (e.g., $\sigma_c^2=1$ and 2 for BPSK and quaternary phase shift keying (QPSK), respectively). For differential detection of DPSK, assuming Gaussian noise and interference, the BER is given by [1],

$$P_e = \frac{1}{2} E \left[e^{-\gamma_i} \right] = \frac{1}{2} E \left[e^{-\mathbf{u}_d^\dagger \mathbf{R}_{nn}^{-1} \mathbf{u}_d} \right]. \quad (4)$$

Thus, the BER expression for both cases differs only by a constant, and we will now consider the term $E \left[e^{-\mathbf{u}_d^\dagger \mathbf{R}_{nn}^{-1} \mathbf{u}_d} \right]$.

Diagonalizing \mathbf{R}_{nn} by a unitary transformation Ψ , we obtain,

$$\mathbf{R}_{nn} = \Psi^\dagger \text{diag} \left[\lambda_1 \cdots \lambda_M \right] \Psi, \quad (5)$$

where $\text{diag}(\cdot)$ denotes an $M \times M$ matrix with nonzero elements only on the diagonal, or,

$$\mathbf{u}_d^\dagger \mathbf{R}_{nn}^{-1} \mathbf{u}_d = \mathbf{u}_d^\dagger \Psi^\dagger \text{diag} \left[\lambda_1^{-1} \cdots \lambda_M^{-1} \right] \Psi \mathbf{u}_d. \quad (6)$$

Let

$$\mathbf{C} = \left[c_1 \cdots c_M \right]^T = \Psi \mathbf{u}_d. \quad (7)$$

Then,

$$E \left[e^{-\mathbf{u}_d^\dagger \mathbf{R}_{nn}^{-1} \mathbf{u}_d} \right] = E \left[e^{-\sum_{n=1}^M \frac{|c_n|^2}{\lambda_n}} \right] = E \left[\prod_{n=1}^M e^{-\frac{|c_n|^2}{\lambda_n}} \right]. \quad (8)$$

Since with independent, Rayleigh fading at each antenna, the elements of \mathbf{u}_d are i.i.d. complex Gaussian random variables, the elements of \mathbf{C} are also i.i.d. complex

Gaussian random variables with the same mean and variance. Furthermore, the λ_n 's are independent of the c_n 's. Thus, we can average over the desired and interfering signal vectors separately, i.e.,

$$E \left[\prod_{n=1}^M e^{-\frac{|c_n|^2}{\lambda_n}} \right] = E_\lambda \left[\prod_{n=1}^M E_{c_n} \left[e^{-\frac{|c_n|^2}{\lambda_n}} \right] \right]. \quad (9)$$

Since the c_n 's are complex Gaussian random variables with zero mean and unit variance,

$$E_{c_n} \left[e^{-\frac{|c_n|^2}{\lambda_n}} \right] = \frac{1}{1 + \frac{1}{\lambda_n}}, \quad (10)$$

and

$$E \left[e^{-\mathbf{u}_d^\dagger \mathbf{R}_{nn}^{-1} \mathbf{u}_d} \right] = E_\lambda \left[\prod_{n=1}^M \left(\frac{1}{1 + \frac{1}{\lambda_n}} \right) \right]. \quad (11)$$

Since the λ_n 's are nonnegative,

$$\frac{1}{1 + \frac{1}{\lambda_n}} \leq \lambda_n, \quad (12)$$

and, therefore,

$$E \left[e^{-\mathbf{u}_d^\dagger \mathbf{R}_{nn}^{-1} \mathbf{u}_d} \right] \leq E_\lambda \left[\prod_{n=1}^M \lambda_n \right] = E_\lambda \left[|\mathbf{R}_{nn}| \right], \quad (13)$$

where $|\mathbf{R}_{nn}|$ denotes the determinant of \mathbf{R}_{nn} .

Since (13) is the key inequality in our bound (and is the only inequality we use in determining the bound for differential detection of DPSK), let us examine its accuracy. The bound is tight if $\lambda_n \ll 1$, and since the λ_n 's are proportional to the interference signal powers, the bound is tight for large received SINR, i.e., low BER's.

Although for all cases $\left(1 + \frac{1}{\lambda_n} \right)^{-1} < 1$ and thus BER < 0.5, for $\lambda_n > 1$ the BER as given by the bound may exceed 0.5. Thus, with small received SINR, occasionally BER's greater than 0.5 may be averaged into the average BER, reducing the tightness of the bound. Also, note that with only noise at the receiver, $\lambda_n = \sigma_n^2$, where σ_n^2 is the variance of the noise normalized to the received desired signal power, and from (4) and (13),

$$P_e \leq \frac{\left(\sigma_n^2 \right)^M}{2} = \frac{1}{2\rho^M}, \quad (14)$$

where ρ is the received SINR, while the actual BER is $\frac{1}{2(1+\rho)^M}$ [1]. Thus, even without interference, the bound differs from the actual BER, and this difference increases as the received SINR decreases.

Let us consider the case of interference only. In this case, $|\mathbf{R}_{nn}|$, which is given by (2), may also be expressed as

$$|\mathbf{R}_{nn}| = |\mathbf{Q}^T \mathbf{Q}| = \sum \pm \mathbf{D}_1^T \mathbf{D}_1 \mathbf{D}_2^T \mathbf{D}_2 \cdots \mathbf{D}_M^T \mathbf{D}_M \quad (15)$$

where $\mathbf{Q} = [\mathbf{D}_1 \cdots \mathbf{D}_M]$, $\mathbf{D}_i = [(\mathbf{u}_1)_i \cdots (\mathbf{u}_L)_i]^T$, $(\mathbf{u}_j)_i$ is the i th element of \mathbf{u}_j , the sum is extended over all $M!$ permutations of 1, 2, ..., M , the "+" sign is assigned for even permutations, and the "-" sign for odd permutations. Now,

$$E[\mathbf{D}_i^T \mathbf{D}_i] = \sum_{j=1}^L \sigma_j^2, \quad (16)$$

where σ_j^2 is the average power of the j th interferer normalized to the desired signal power, and

$$E[\mathbf{D}_i^T \mathbf{D}_i \mathbf{D}_i^T \mathbf{D}_i] = \sum_{j=1}^L \sigma_j^4. \quad (17)$$

Similarly, from (15), it can be shown that

$$E[|\mathbf{Q}^T \mathbf{Q}|] = \sum_{i_1} \alpha_{i_1}^{(M)} \left(\sum_{j=1}^L \sigma_j^2 \right)^{M - \sum_{i_1} i_1} \left(\sum_{j=1}^L \sigma_j^{2i_1} \right)^{i_1} \cdot \left(\sum_{j=1}^L \sigma_j^{2i_2} \right)^{i_2} \cdots, \quad (18)$$

where the $\alpha_{i_1}^{(M)}$'s are integers (determined below) and the sum is over all i_k and l_k that exist such that $M \geq \cdots > i_2 > i_1 \geq 1$, with $\sum_{i_1} i_1 \leq M$. Since $\sum_{j=1}^L \sigma_j^2 = 1/\rho$, and $\alpha_{i_1}^{(M)} = 1$ when $\sum_{i_1} i_1 = 0$, (18) can also be expressed as

$$E[|\mathbf{Q}^T \mathbf{Q}|] = \rho^{-M} \left[1 + \sum_{i_1} \alpha_{i_1}^{(M)} \left(\sum_{j=1}^L \rho \sigma_j^2 \right)^{i_1} \cdot \left(\sum_{j=1}^L \rho \sigma_j^2 \right)^{i_2} \cdots \right], \quad (19)$$

where now $M \geq \cdots > i_2 > i_1 > 1$.

To determine the $\alpha_{i_1}^{(M)}$'s, first note that if $\sigma_j^2 = \sigma^2$, $j=1, \dots, L$, then $\sum_{j=1}^L \sigma_j^{2k} = L\sigma^{2k}$, and (19) becomes,

$$E[|\mathbf{Q}^T \mathbf{Q}|] = \left[L^M + \sum_{k=2}^M \beta_k L^{M-k+1} \right] \sigma^{2M}, \quad (20)$$

where the β_k 's and the $\alpha_{i_1}^{(M)}$'s can be seen to be closely related. From [7], $P_e = 0$ for $L < M$, and thus the β_k 's are the coefficients of the M th order polynomial in L , $L(L-1)(L-2)\cdots(L-M+1)$. This result is not only useful when all interferers have equal power, but also serves as a consistency check on our calculated values of $\alpha_{i_1}^{(M)}$.

The values of $\alpha_{i_1}^{(M)}$ were generated using a computer program to examine every permutation in (15) for given

M . The number of each type of $i_1, l_1, i_2, l_2, \dots$ term was calculated to determine $\alpha_{i_1}^{(M)}$. Table 1 lists these values for $M=2$ to 7. Note that only i_1 and l_1 terms exist for $M \leq 4$, and i_2 and l_2 terms also exist for $5 \leq M$. Values for $\alpha_{i_1}^{(M)}$ for higher M can also be easily calculated. However, since the amount of computer time to generate the values of $\alpha_{i_1}^{(M)}$ increases exponentially with M , our program could only generate these values in a reasonable amount of computer time for up to $M=10$ (where a hundred cpu hours on a SPARC10 would be required).

From (3), the upper bound on the BER with coherent detection of BPSK or QAM is now given by

$$P_e \leq e^{-\left[\frac{1}{\sigma_c^2} - 1 \right]} \rho^{-M} \left[1 + \sum_{i_1} \alpha_{i_1}^{(M)} \left(\sum_{j=1}^L \left[\rho \sigma_j^2 \right]^{i_1} \right)^{i_1} \cdot \left(\sum_{j=1}^L \left[\rho \sigma_j^2 \right]^{i_2} \right)^{i_2} \cdots \right], \quad (21)$$

and from (4), the upper bound on the BER with differential detection of DPSK is given by

$$P_e \leq \frac{1}{2} \rho^{-M} \left[1 + \sum_{i_1} \alpha_{i_1}^{(M)} \left(\sum_{j=1}^L \left[\rho \sigma_j^2 \right]^{i_1} \right)^{i_1} \cdot \left(\sum_{j=1}^L \left[\rho \sigma_j^2 \right]^{i_2} \right)^{i_2} \cdots \right]. \quad (22)$$

For the case of noise with L interferers, consider the noise as an infinite number of weak interferers with total power equal to the noise. That is, let

$$\sigma_j^2 = \frac{\sigma_n^2}{K-L}, \quad j=L+1, \dots, K, \quad (23)$$

and let $K \rightarrow \infty$. Then, $\rho = \left[\sum_{j=1}^L \sigma_j^2 + \sigma_n^2 \right]^{-1}$, and

$$\lim_{K \rightarrow \infty} \left[\left(\sum_{j=1}^K \sigma_j^{2i_k} \right)^{i_k} \right] = \left[\left(\sum_{j=1}^L \sigma_j^{2i_k} \right)^{i_k} \right], \quad (24)$$

for $i_k > 1$. Therefore, with noise, the BER bound is the same as in (21) and (22), but with ρ including the noise. In this case, if we define the received desired signal-to-noise ratio as $\Gamma_d = \frac{\sigma_s^2}{\sigma_n^2}$ and the j th interferer signal-to-noise ratio as $\Gamma_j = \frac{\sigma_j^2}{\sigma_n^2}$, then (22) becomes (similarly for (21)),

$$P_e \leq \frac{1}{2\rho^M} \left[1 + \sum_{i_1} \alpha_{i_1}^{(M)} \left(\sum_{j=1}^L \left[\frac{\Gamma_j}{\sum_{j=1}^L \Gamma_j + 1} \right]^{i_1} \right)^{i_1} \cdot \left(\sum_{j=1}^L \left[\frac{\Gamma_j}{\sum_{j=1}^L \Gamma_j + 1} \right]^{i_2} \right)^{i_2} \cdots \right]. \quad (25)$$

TABLE 1
Values of $\alpha_{ii}^{(M)}$ for $M=2$ to 7

M	i_1	l_1	i_2	l_2	$\alpha_{ii}^{(M)}$
2	2	1			-1
3	2	1			-3
	3	1			+2
4	2	1			-6
	2	2			+3
	3	1			+8
	4	1			-6
5	2	1			-10
	2	2			+15
	3	1			+20
	2	1	3	1	-20
	4	1			-30
	5	1			+24
6	2	1			-15
	2	2			+45
	2	3			-15
	3	1			+40
	3	2			+40
	4	1			-90
	5	1			+144
	6	1			-120
	2	1	3	1	-120
	2	1	4	1	+90
7	2	1			-21
	2	2			+105
	2	3			-105
	3	1			+70
	3	2			+280
	4	1			-210
	5	1			+504
	6	1			-840
	7	1			+720
	2	1	3	1	-420
	2	1	4	1	+630
	2	1	5	1	-504
	3	1	4	1	-420
	2	2	3	1	+210

Since $\frac{1}{2\rho^M}$ is the bound with maximal ratio combining, the term in the brackets is the improvement of optimum combining over maximal ratio combining based on the BER bound. Defining the gain of optimum combining as the reduction in the required ρ for a given BER, from (25), this gain in dB is given by,

$$\text{Gain(dB)} = -\frac{10}{M} \log_{10} \left[1 + \sum_{ii} \alpha_{ii}^{(M)} \left(\frac{\sum_{j=1}^L \Gamma_j}{\sum_{j=1}^L \Gamma_j + 1} \right)^{i_1} \right]^{l_1} \cdot \left(\frac{\sum_{j=1}^L \Gamma_j}{\sum_{j=1}^L \Gamma_j + 1} \right)^{i_2} \right]^{l_2} \dots \quad (26)$$

This gain is therefore independent of the desired signal power (because the bound is asymptotically tight as $\rho \rightarrow \infty$). However, this is the gain of the BER bound with optimum combining over the BER bound with maximal ratio combining. Since the required ρ for a given BER with maximal ratio combining is less than the bound, the true gain may differ from (26) and to obtain a bound on the gain, the gain in (26) must be reduced accordingly. For example, with differential detection of DPSK, to obtain a bound the gain given in (26) is reduced by the factor $\left[\frac{\rho}{1+\rho} \right]^M$. Note that as $\rho \rightarrow \infty$, this factor reduces to one and the gain approaches (26). Thus, we will refer to (26) as the asymptotic gain.

III. COMPARISON TO THEORY AND SIMULATION

In this section, we compare the bound to theoretical results for $L=1$ and simulation results for $L \geq 2$.

Figure 2 compares theoretical results (from [1-4]) for the gain to the asymptotic gain (26) versus BER with coherent detection of BPSK for $L=1$. Results are generated for $M=2$ and 5, and $\Gamma_1=3$ and 10 dB. In all cases the gain monotonically decreases to the asymptotic gain as the BER decreases. The gain approaches the asymptotic gain more slowly with decreasing BER for larger M and also, at low BER's, the accuracy of the asymptotic gain decreases with higher Γ_1 . Thus, the accuracy of the asymptotic gain decreases as the ρ required for a given BER with optimum combining decreases, as predicted by the approximation in Section II.

Figure 3 compares Monte Carlo simulation results [4] for the gain to the asymptotic gain for $L=2$ and 6. Results are plotted versus M with $\Gamma_j=3$ dB for all interferers and coherent detection of BPSK at a 10^{-3} BER. The asymptotic gain has the same shape as the simulation results. The cases include both many more interferers than antennas and many more antennas than interferers, but in all cases the asymptotic gain is within 1.8 dB of simulation results.

Comparison of Monte Carlo simulation results [4] for the gain to the asymptotic gain for the other cases in [4], including different Γ_j 's, also showed that the asymptotic gain has the same shape as the simulation results and is within 2 dB of the simulation results.

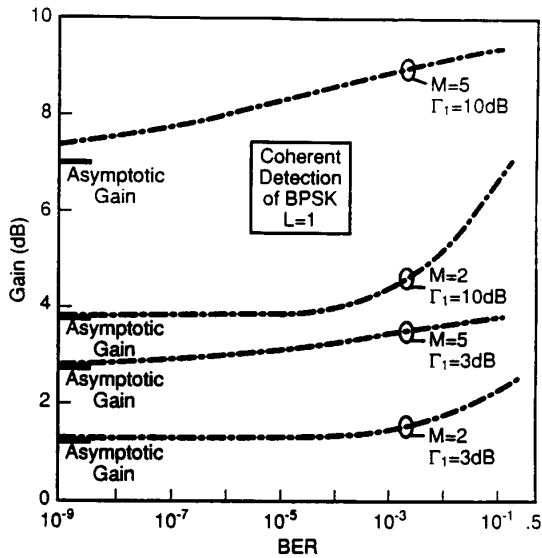

Figure 2 Gain versus BER for coherent detection of BPSK - comparison of analytical results to the asymptotic gain.

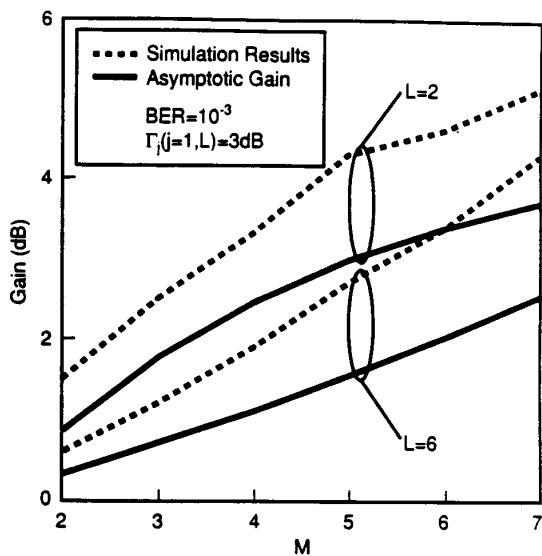

Figure 3 Gain versus M with two and six equal power interferers - comparison of Monte Carlo simulation results with coherent detection of BPSK [4] to the asymptotic gain.

IV. CONCLUSIONS

In this paper we have presented upper bounds on the bit error rate (BER) of optimum combining in wireless systems with multiple cochannel interferers in a Rayleigh

fading environment. We presented closed-form expressions for the upper bound on the bit error rate with optimum combining, for any number of antennas and interferers, with coherent detection of BPSK and QAM signals, and differential detection of DPSK. We also presented bounds on the performance gain of optimum combining over maximal ratio combining and showed that these bounds are asymptotically tight with decreasing BER. Results showed that the asymptotic gain is within 2 dB of the gain as determined by computer simulation for a variety of cases at a 10^{-3} BER. These cases include interference scenarios that cover the range of worst to best cases for the gain of optimum combining in cellular systems with $M=2$. The bound is most accurate with differential detection of DPSK and high SINR, corresponding to low BER and a few antennas. The closed-form expression for the bound permits rapid calculation of the improvement with optimum combining for any number of interferers and antennas, as compared with the cpu hours previously required by Monte Carlo simulation. These bounds allow calculation of the performance of optimum combining under a variety of conditions where it was not possible previously, including analysis of the outage probability with shadow fading and the combined effect of adaptive arrays and dynamic channel assignment in mobile radio systems.

V. REFERENCES

- [1] W. C. Jakes Jr., et al., *Microwave Mobile Communications*, Wiley, New York, 1974.
- [2] V. M. Bogachev and I. G. Kiselev, "Optimum combining of signals in space-diversity reception," *Telecommunications and Radio Engineering*, vol. 34/35, no. 10, p. 83, Oct. 1980.
- [3] M. J. Gans, "Dual polarization communication in a scattered propagation environment to double spectrum usage," unpublished paper.
- [4] J. H. Winters, "Optimum combining in digital mobile radio with cochannel interference," *IEEE Journal on Selected Areas in Communications*, vol. SAC-2, no. 4, July 1984.
- [5] J. H. Winters, "Optimum combining for indoor radio systems with multiple users," *IEEE Transactions on Communications*, vol. COM-35, no. 11, November 1987.
- [6] J. H. Winters, "Signal acquisition and tracking with adaptive arrays in the digital mobile radio system IS-54 with flat fading," *IEEE Trans. on Vehicular Technology*, November 1993.
- [7] J. H. Winters, J. Salz, and R. D. Gitlin, "The impact of antenna diversity on the capacity of wireless communication systems," *IEEE Trans. on Commun.*, April 1994.
- [8] R. A. Monzingo and T. W. Miller, *Introduction to Adaptive Arrays*, John Wiley and Sons, New York, 1980.
- [9] G. J. Foschini and J. Salz, "Digital communications over fading radio channels," *Bell System Technical Journal*, vol. 62, pp. 429-456, Feb. 1983.